

iliad



1st Half 2006 Results Presentation

Iliad: First Mover in France since 1994

iliad

What is the next step?

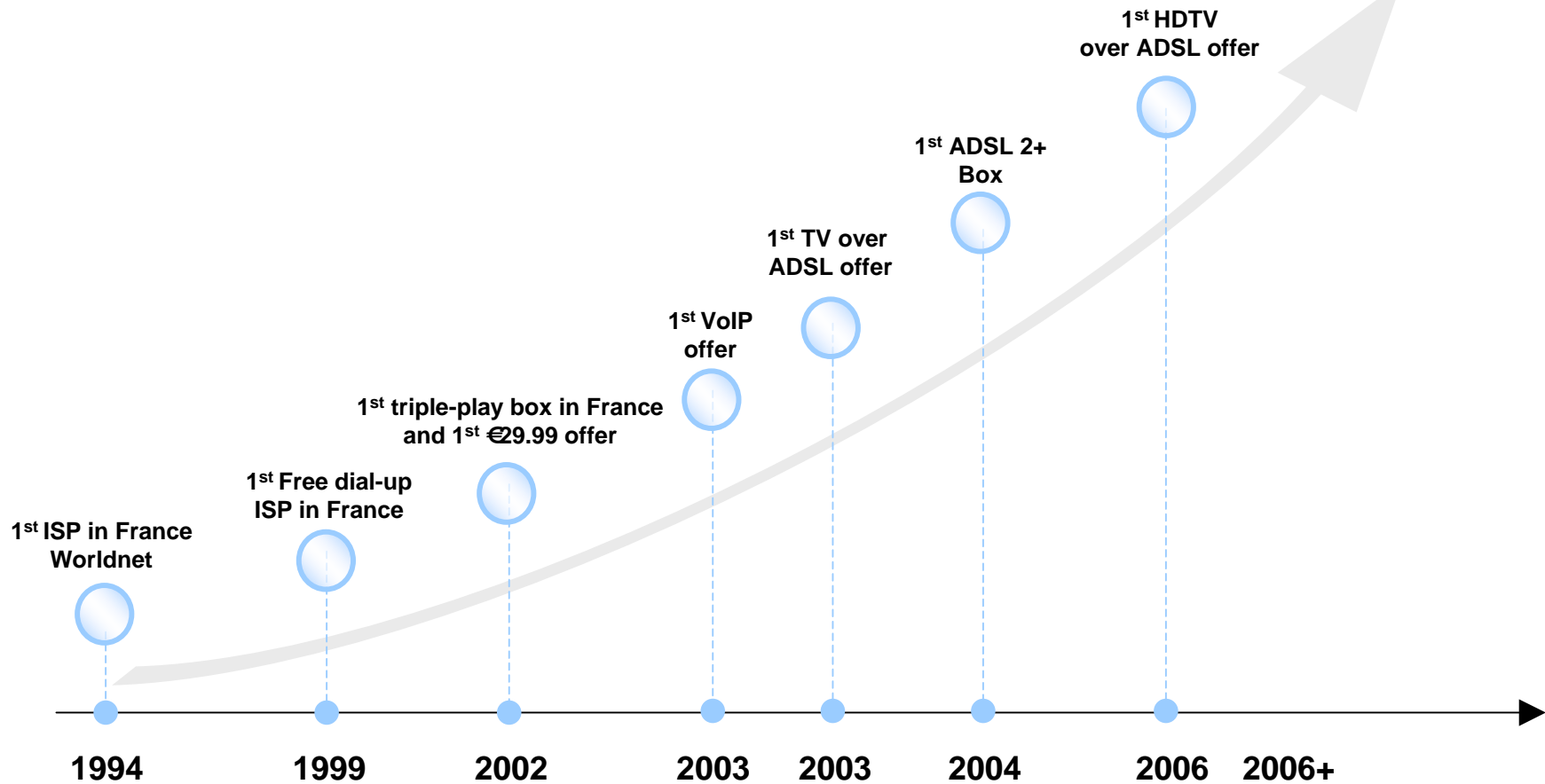

- **Iliad will be the 1st operator to introduce “mass-market” FTTH**
 - Paris to be the first European fiber capital
- **FTTH is the logical extension of Iliad’s strategy in broadband**
 - FTTH guarantees total independence on the local loop
- **Iliad’s investment decision based on current situation**
 - Over 2 million broadband subscribers by year end
 - 25,000 kms of existing fiber network
 - €33.5 ARPU
 - Cash position and FCF reinvestment
- **FTTH is a future-proof technology**

iliad



1st Half 2006 Results

- **Only national Wimax licence**

- Auction resulted in “patchwork” footprint for others
- Attractive price

- **New Freebox services launched**

- TV:

- Free Digital PVR activated on Hard Drive

- VoD:

- Canalplay Kids (Cartoons)
- i-Concerts (Music videos)

- Telephony over ADSL:

- Additional free international phone destinations included

- **New “Naked” ADSL offer at €29.99 in non-unbundled areas**

- Only offer to include FT line rental



Record ADSL Net Adds in 1H06



- **1,905,000 ADSL subscribers as of June 30, 2006**
→ 18.2% market share
- **Growth accelerating in 2006**
→ Customer acquisition¹ cost below €50 in 1H06

Quarterly ADSL Net Adds

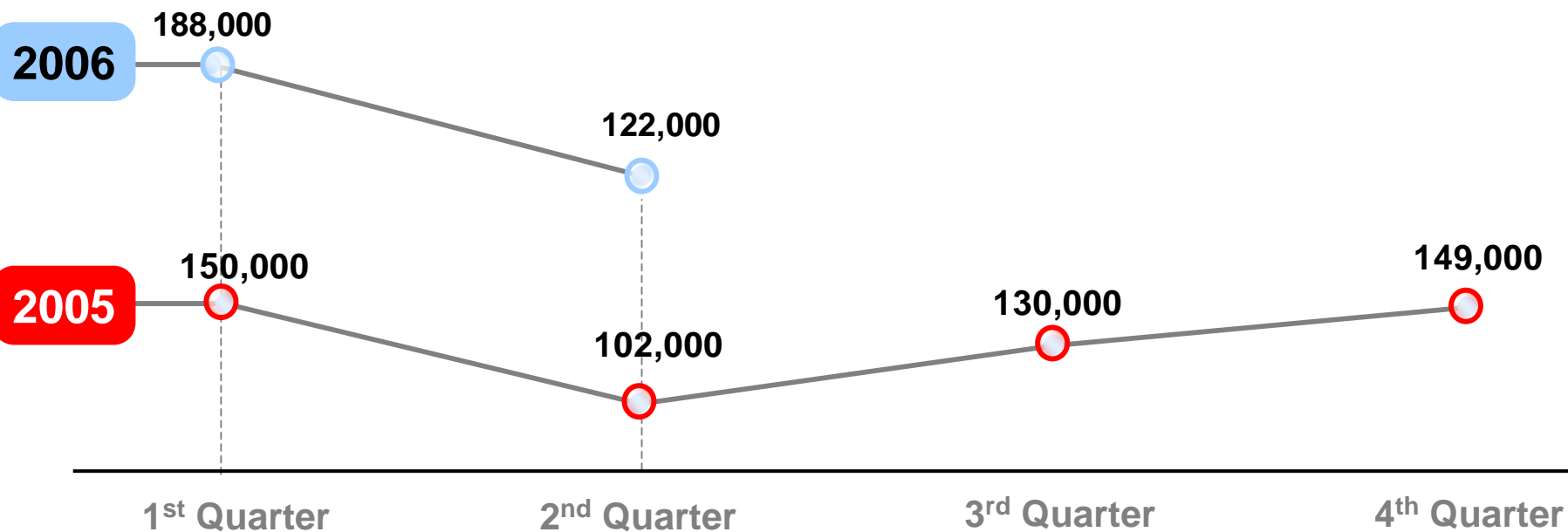

Source : France Telecom for market share

(1) Customer acquisition cost = Gross marketing expenses / Net adds

Freebox HD : The Most Advanced ADSL Solution in Europe

iliad

- Launched in April 2006 after 18 months of in-house research
- 4 critical evolutions:
 - Wifi MIMO: enhanced Wifi for security and TV usage
 - DTT: TF1 and M6 available on Freebox in digital quality
 - HD: 1st HDTV over ADSL offer
 - mobile telecommunication on Wifi: SIP
- Other innovations to come....



1H06 : Group Net Income Up 143% yoy



<i>In € '000</i>	1H05	1H06	Var.	FY 2005
Revenues	337,832	447,938	+ 32.6%	724,201
EBITDA	94,916	152,952	+ 61.1%	224,313
EBITDA Margin	28.1%	34.1%	-	31.0%
EBIT	39,210	89,528	+ 128.3%	107,686
EBIT Margin	11.6%	20.0%	-	14.9%
Net Income	24,127	58,604	+ 142.9%	68,898

1H06 : Steady Profitability Improvements



EBITDA Margin

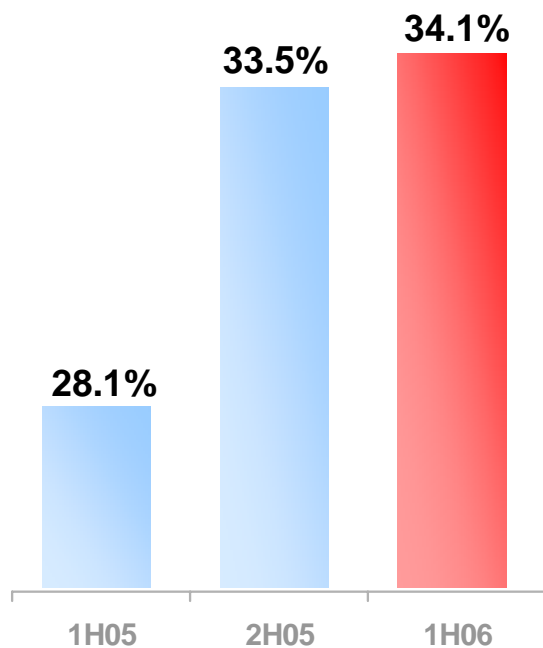

EBIT Margin

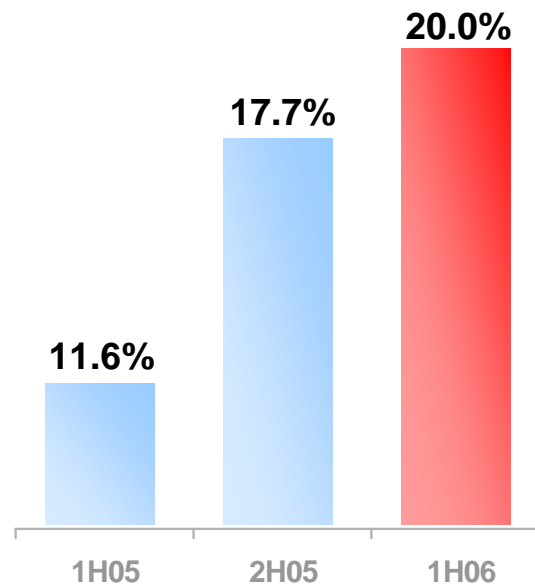

Net Margin

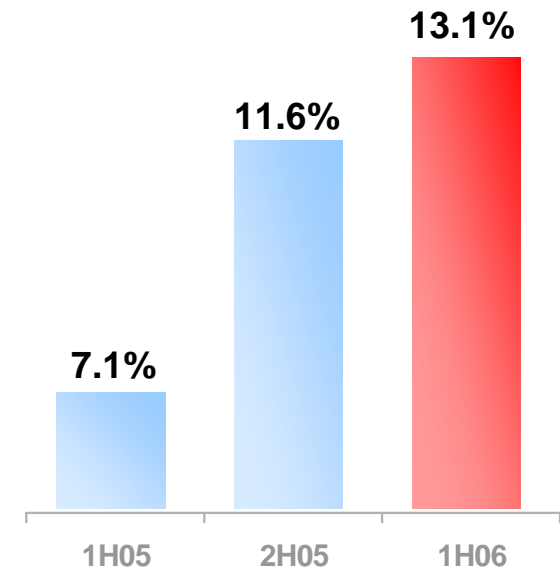

Broadband : Revenues and ARPU Growth



In € million

Revenues⁽¹⁾

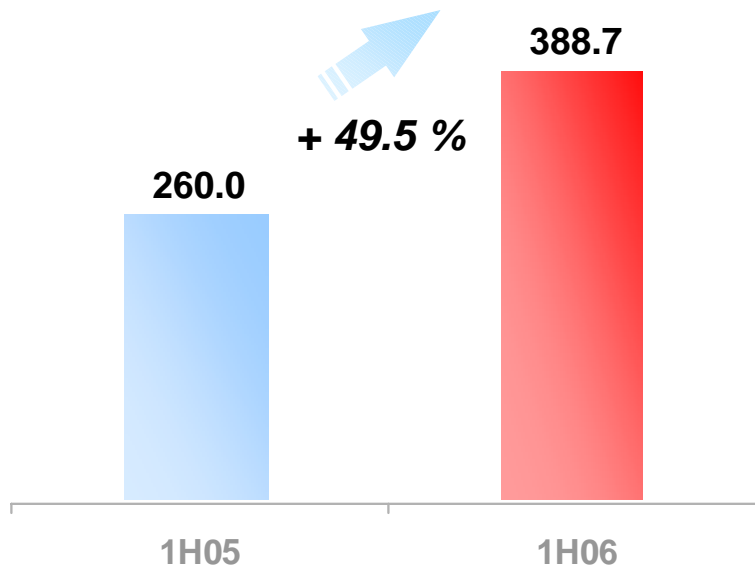

Value Added Services Revenues

- Broadband ARPU at €33.5 in 2Q06
- VAS revenues at 19% of BB revenues

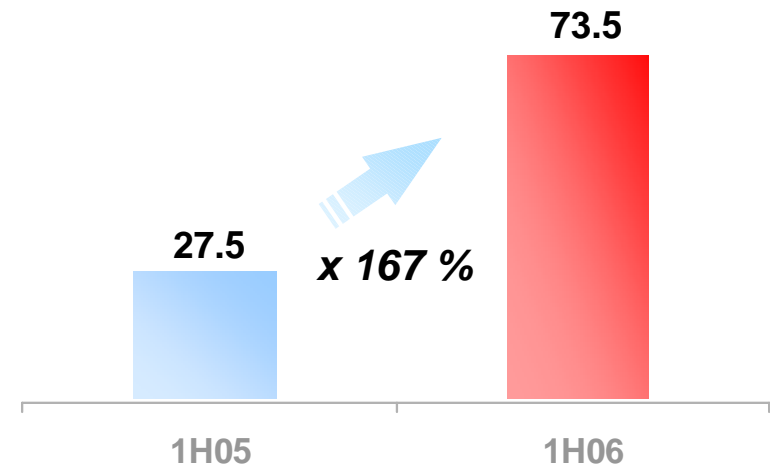

(1) Excluding intersegment

Broadband : Strong EBITDA Growth

iliad

In € million

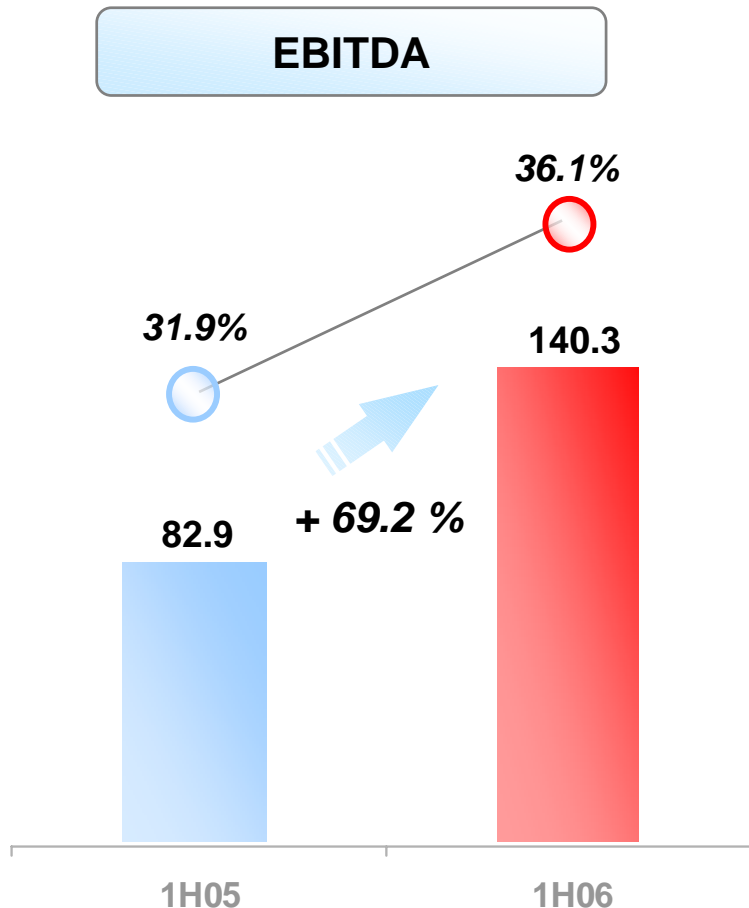

- **Gross margin per unbundled subscriber exceeded €20 in 1H06**
 - Approx. 50% Full ULL subscribers
- **EBITDA margin at 36.1% flat vs. 2H05**
 - Marginal unbundling ratio increase at 72.3% (June 06) vs. 67.1% (June 05)
 - Stock option plan
 - WiMax operating costs
 - Heavier operating tax charges (other than corporate tax): additional €1.2 million
- **Marketing budget entirely transferred from Traditional Telephony to Broadband**
 - Under €50 customer acquisition cost in 2006

Broadband : Record EBIT Margin

iliad

In € million

EBIT

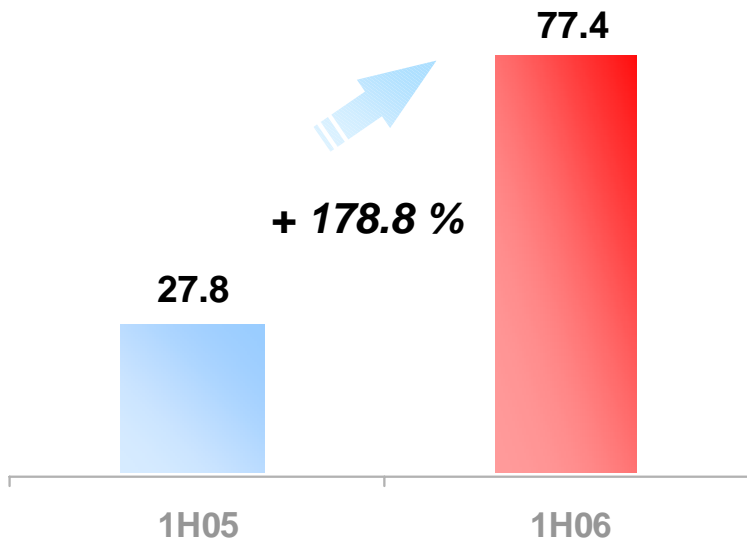

- **Delivering strong operating leverage**
 - 20% EBIT margin vs. 10.7% in 1H05
- **Network 100% DSLAM V2**
 - DSLAM V1 fully amortized at end 2005
 - Total depreciation at €62.9 million, up 14%

Traditional Telephony : Declining but Profitable



In € million

Revenues⁽¹⁾

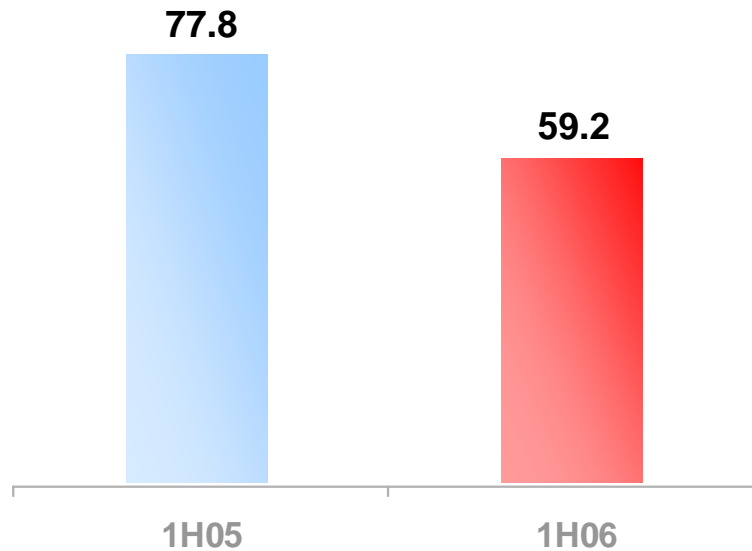

EBITDA

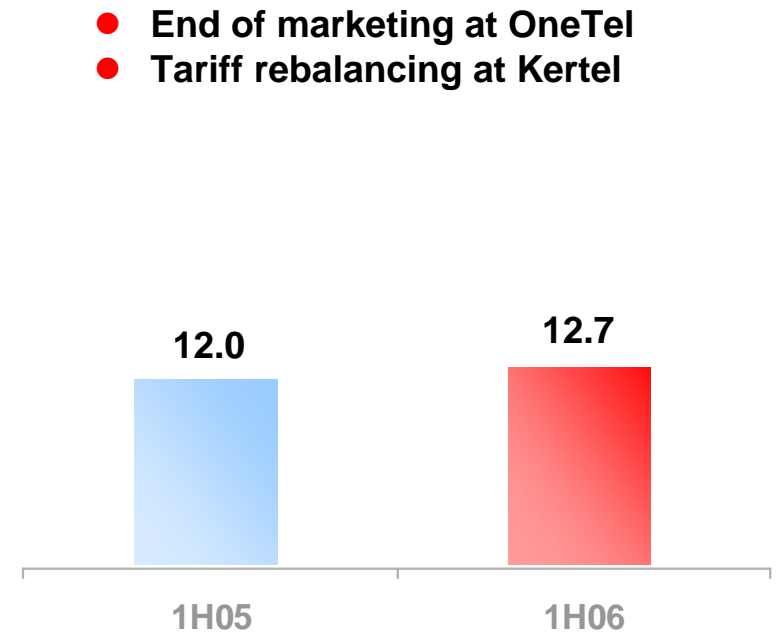

- End of marketing at OneTel
- Tariff rebalancing at Kertel

(1) Excluding intersegment

1H06 CAPEX Breakdown



In € million

Network CAPEX

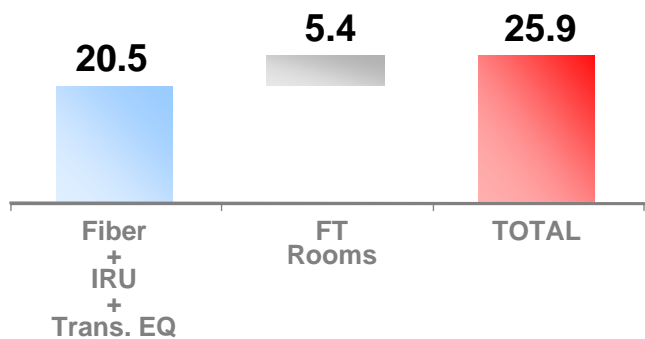

Growth CAPEX

- Record ADSL net adds in 1H06
- Freebox HD + DSLAM at approx. €220

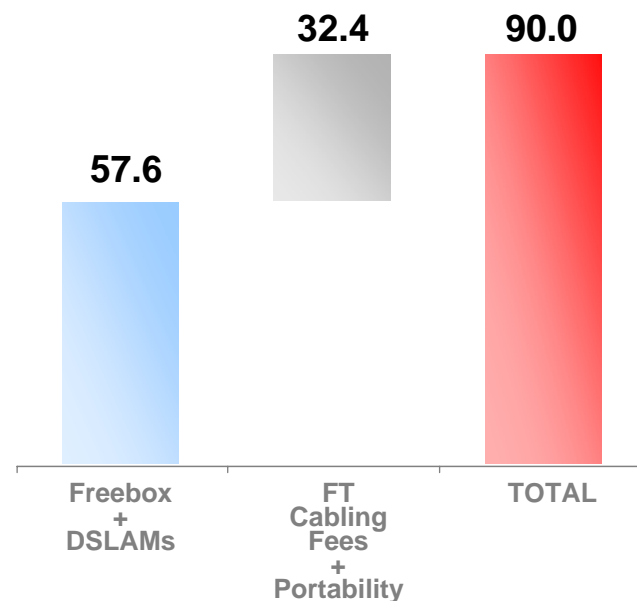

Positive Free Cash Flow in 1H06

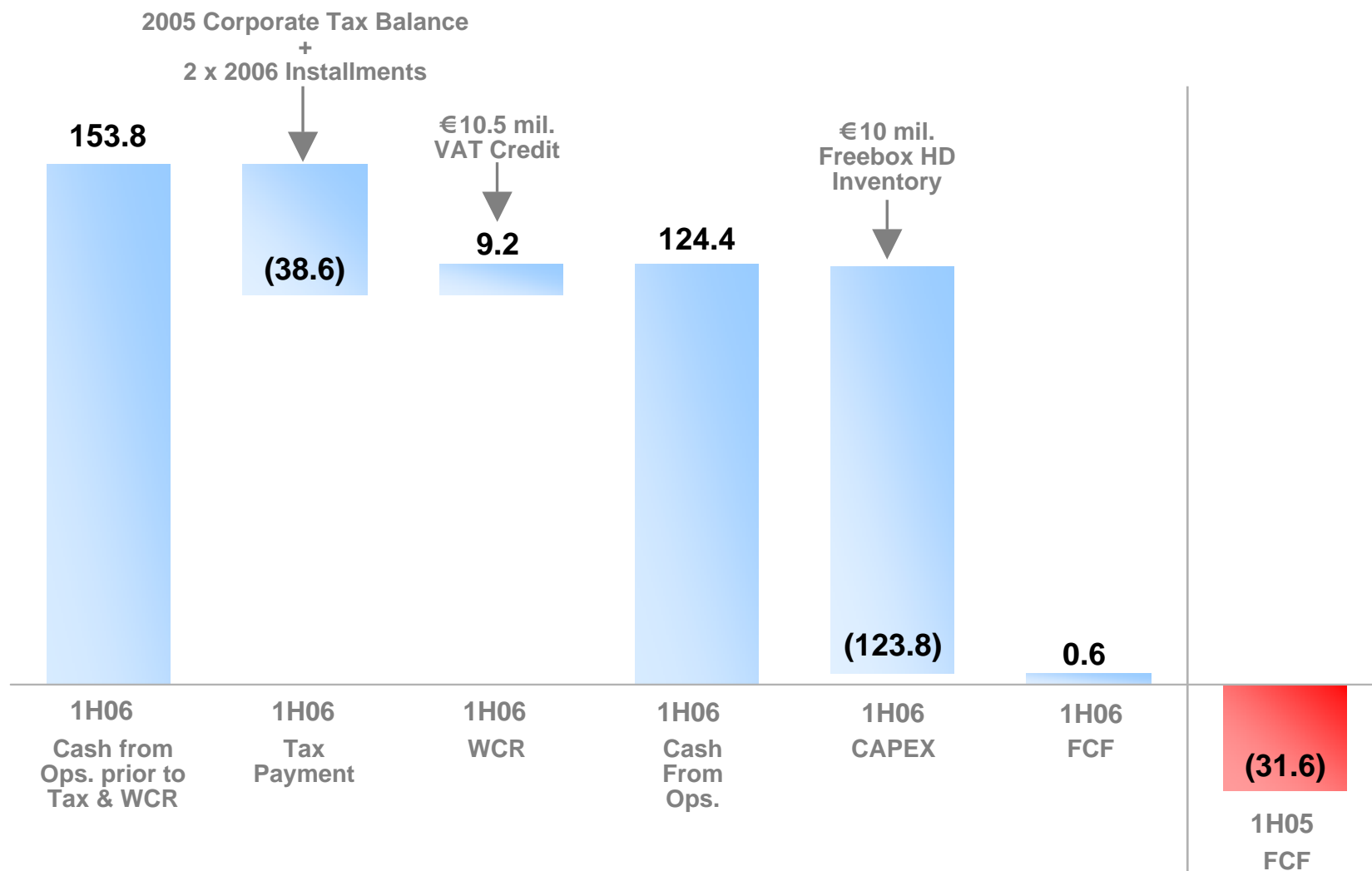

Strong Balance Sheet Structure

iliad

In € million

Cash & Equivalents

+ €179 million undrawn credit facilities

366.4

51.1

12/2005

06/2006

Net Financial Debt

38.5

12/2005

5.4

06/2006

Equity

248.6

12/2005

319.6

06/2006

Maintain Free at the forefront of innovation

€20 gross margin per ULL subscriber

Reach 75% unbundled subscribers by end 2006

Generate positive FCF from current businesses

1 Alternative operator for residential market in France

iliad

 **Bringing Broadband to the Next Frontier**

Fiber to the Home (FTTH) : The Final Step in Broadband

iliad

- **Iliad plans to roll out a fiber network with dedicated access in every subscriber's home**
 - Selected fiber areas to coexist with ADSL 2+ areas
- **FTTH rationale**
 - Total technological independence on the local loop
 - Unique differentiation vs. competitors
 - Ultimate bandwidth quality
 - Unlimited speed and future developments
 - Significant market share improvement potential



Bandwidth Usage Continuously Rising



Potential Applications

Multi TV HD Broadcast
Symmetrical Bandwidth
Self Produced Content

HDTV - VoD
Fast Games

Internet - TV
Music - Games

E-Mail - Internet

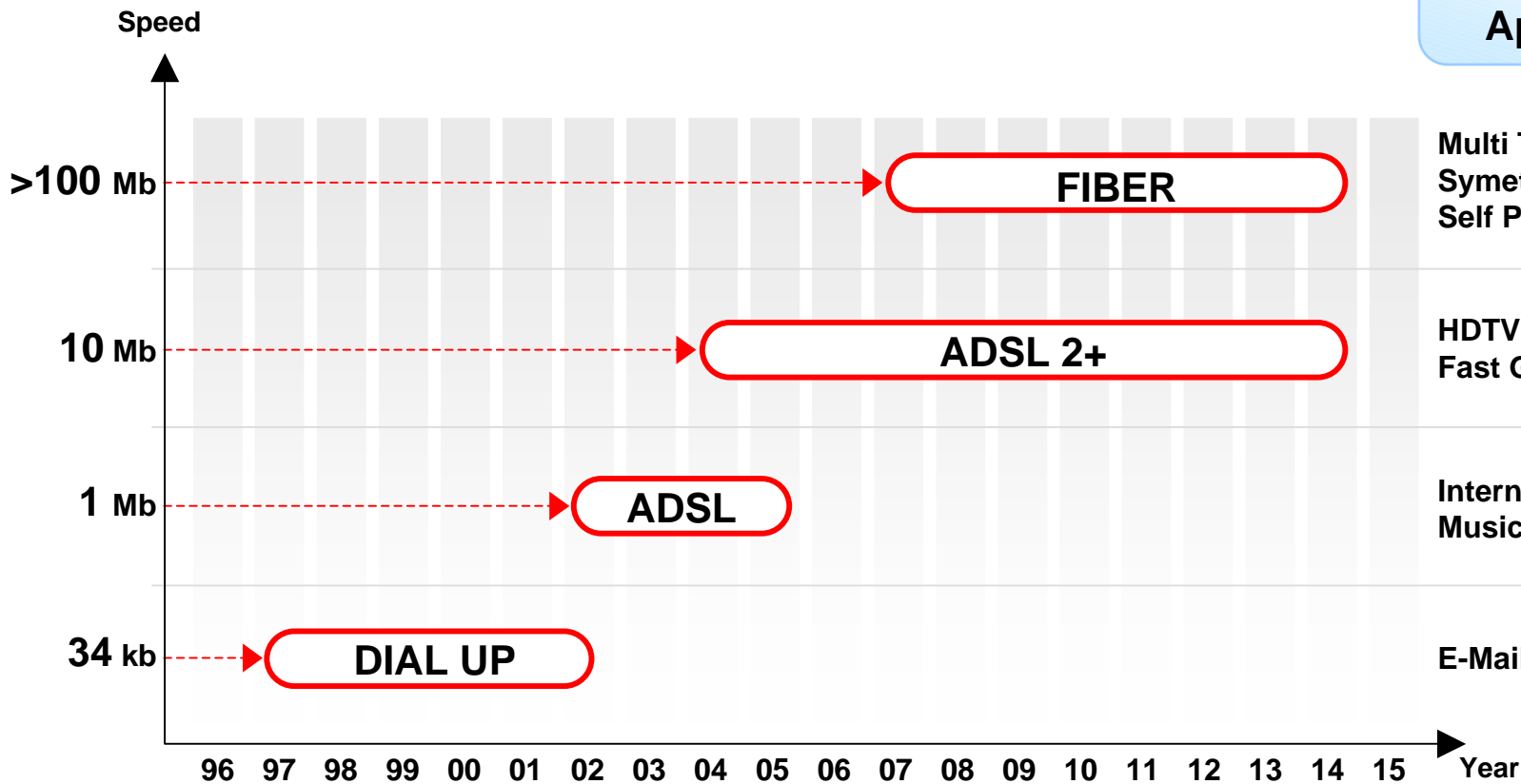

Iliad: A Unique Platform to Build the Future of Broadband



- **Operational and technological strength**
 - In-house R&D team since 2000
 - Successful development of Freebox and DSLAM at attractive costs
 - Operating 25,000 Kms of existing fiber network
- **Market strength**
 - Over 2,000,000 broadband subscribers by end 2006
 - Brand recognition second to none
 - Unique knowledge of subscribers' usage and location
- **Financial strength**
 - Proven ability to generate profits across all businesses
 - Only alternative telecom operator to generate FCF
 - Over €650 million of broadband CAPEX since 2000
 - Clear and dedicated ownership structure

Fiber Roll-out : Critical Steps



Network Architecture	Fiber local loop factored in since 2000	
Equipment	Freebox HD : 2 boxes to simplify upgrade to fiber	
Business Plan & Commercial Offer	100% completed	
Team	First hires in January 2006	
Rights of Way	Paris agreements signed in July 2006	
Optical Freebox	Prototypes scheduled for 2006	
Optical POPs (NRO)	100 sites under review	

Fiber Roll-out : Technical Alternatives



PON (FT) : Shared Bandwidth

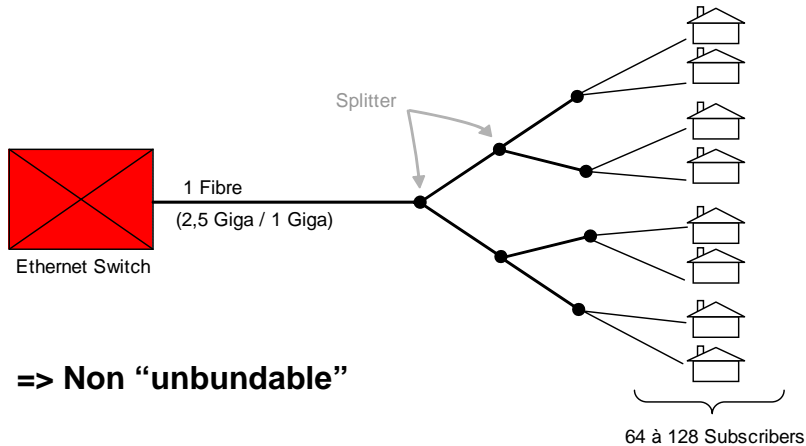

Cable Operators : Fiber + Coax

FTTLA – Fiber To the Last Amplifier

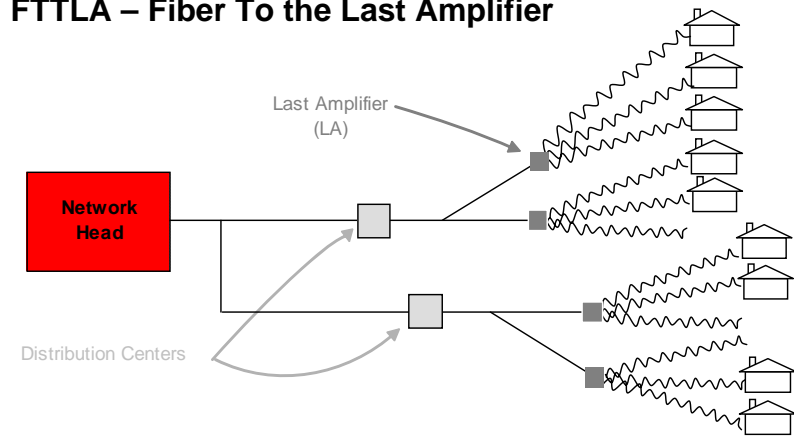

P to P (Iliad) Dedicated Fiber

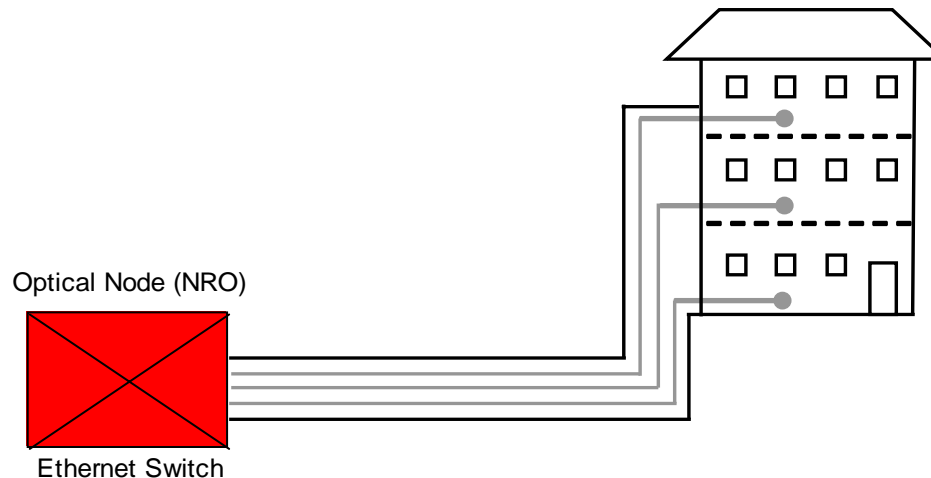

- Dedicated fiber from the NRO to the subscriber
- Limitless evolution for end equipments
- No concentration point

- **Fiber not intended to replace ADSL 2+**
 - Fiber areas to coexist with ADSL 2+ areas
- **Selecting fiber areas based on :**
 - Density of existing Free subscribers
 - Cost of civil engineering alternatives
 - Aerial
 - Sewers
 - Micro trenches

Free will target areas/neighbourhoods where it boasts a minimum 15% market share of existing landlines, NOT only ADSL lines

FTTH : The Connection Process Challenge (1/2)



- **Horizontal roll-out :**
 - Entire neighbourhood/areas wired with fiber
 - Fiber cable dropped in the basement of each building
- **Vertical roll-out :**
 - Internal building connection undertaken ONLY IF existing ADSL subscribers
- **On-premise connection :**
 - Free of charge for existing ADSL subscribers
 - Free of charge for new FTTH subscribers registered prior to Vertical roll-out date

FTTH : The Connection Process Challenge (2/2)



- **Horizontal roll-out, vertical roll-out and on-premise connection included in project capex**
- **On-premise connection for new subscribers post Vertical roll-out date :**
 - ➔ **Estimated €350 CAPEX per subscriber including**
 - Installation
 - Optical Freebox + Freebox HD
 - ➔ **An installation fee will apply on a case by case basis**



€29.99 : A Well Established “Mass Market” Price

iliad

- **Free will provide FTTH service at €29.99 per month incl.:**
 - Unlimited very high speed access (50Mbps)
 - Free phone calls to French and selected international landlines
 - HDTV
 - Offer will address residential and SME markets
- **Ultra high bandwidth options (100Mbps +)**
- **Free will migrate 100% of its existing ADSL subscribers in fiber areas**

New Freebox



New Optical Freebox



Existing Freebox HD

Groundbreaking New Universal Service Offer (1/2)



- **Free will propose an FTTH offer completely free of charge**
- **Households located in buildings and social housing already cabled by Iliad will have access to :**
 - Low bandwidth Internet + mail access only
 - Basic telephony access : incoming calls, emergency calls and social services
 - Digital Terrestrial TV Channels

Groundbreaking New Universal Service Offer (2/2)



- **Free Foundation being created to manage the new Universal Service offer**
 - €10 million personal initial endowment by Xavier Niel
- **Free Foundation will assume the following functions :**
 - Pay for on-premise connection during vertical roll-out
 - Purchase Optical Freebox
 - Receive deposit paid at connection for Optical Freebox

- **Iliad will propose a wholesale fiber loop offer**
 - Subject to technical processes
- **NRO to subscriber rental offer**
 - Prices will allow competitors to replicate Free's commercial offer
- **Iliad will also work closely with local authorities**
 - Local authorities seeking to speed up FTTH roll-out
 - Local authorities seeking an open network provider

- **Cover 4 million households**
 - Over 10 million population
 - Paris and suburbs, boroughs of other cities
- **Target areas where Free has 15% market share of all existing landlines**
- **Up to €1 billion investment until completion**
 - Around €1,500 per existing subscriber
 - ~ €300 million investment in 2006/2007
 - €100 to 150 million per annum in 2008 to 2012

- **6-year cash pay back commitment based on :**
 - Migration of existing subscribers
 - ADSL-like ARPU of €33.5 per month
 - FTTH gross margin significantly higher than ADSL at €30
- **All FT unbundling charges disappear**
 - Incremental cash flow for Iliad
- **Significant sensitivity to market share and ARPU**
 - At 25% market share in year 3, payback accelerates to around 4 years

- **Real differences with xDSL technologies :**
 - Quality (cabling issues, length of loop)
 - Symmetrical bandwidth
 - Speed (virtually unlimited)



- **Promoting new services :**
 - High definition multi TV
 - Self-produced content
 - HD VoD

- **Facilitating new applications :**
 - Medical aftercare
 - Electronic surveillance
 - Education

Iliad : 10 Years of Successful Execution

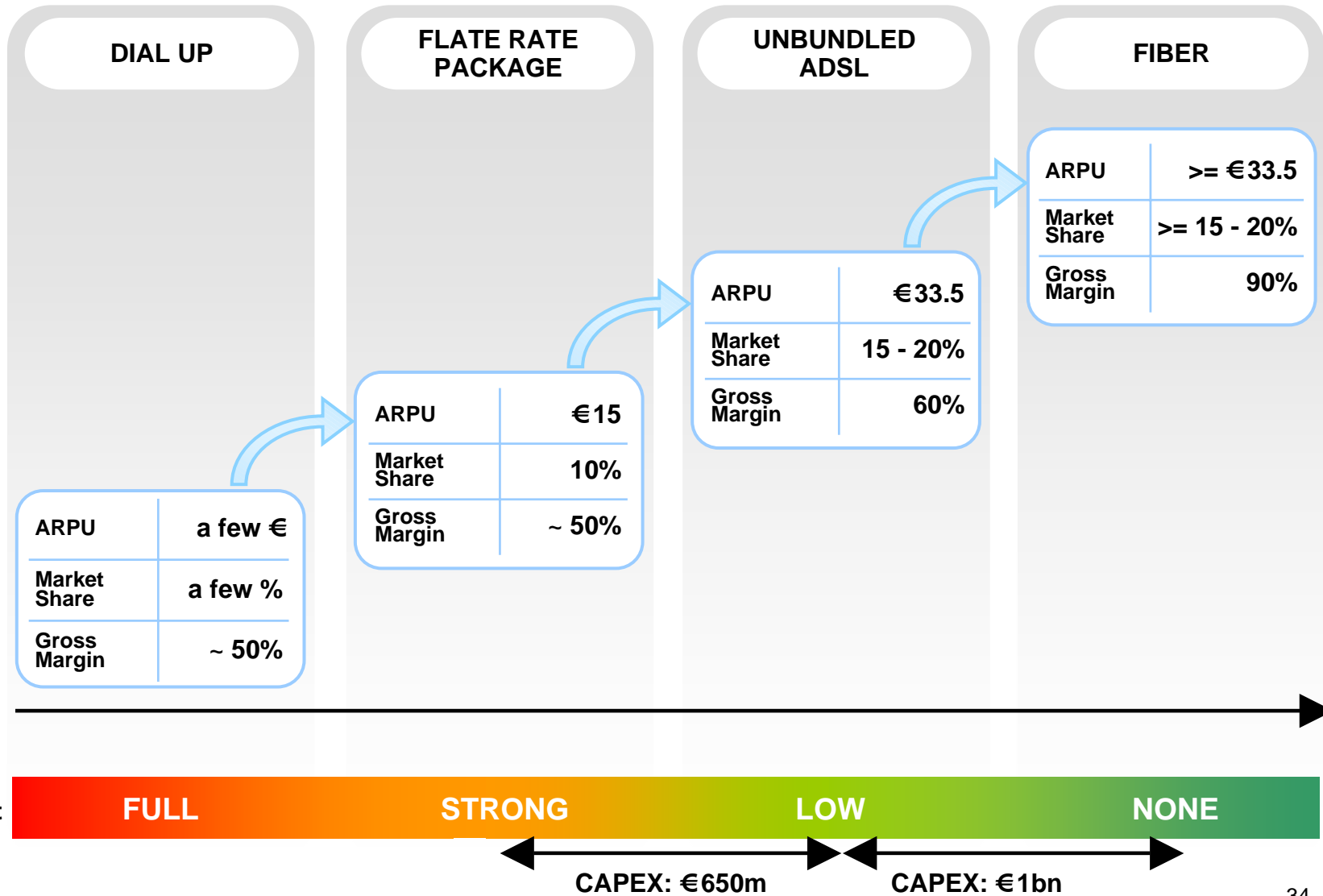

Priority given to the migration of existing ADSL subscribers

Business case built on existing ARPU and market share

Amortization period of 30 years but cash payback period of maximum 6 years

Potential growth drivers : additional ARPU and market share

**Iliad's new benchmarks in European broadband :
Growth, Profitability and Independence**